



ATOM 4K

USER MANUAL

neumi

LET US HELP!

Our friendly customer service team is standing by to answer questions, help with setup, or fix issues.



support@neumitech.com



www.neumitech.com



One Year Warranty

SETUP AND CONNECTIONS

Congratulations on your purchase of the NEUMI ATOM 4K digital media player. We know your time is valuable, so we have configured this media player with optimized default settings that are suitable for most users. This manual contains information on how to adjust the settings to customize your user experience. If you encounter any difficulties or have questions, please email SUPPORT@NEUMITECH.COM and our friendly support team will help you promptly.

In the package are your new media player, an AC power adapter, a remote control, an AV cable, and this user's manual. Take a minute to examine the player to become familiar with the available connectors, this step will save you time later:

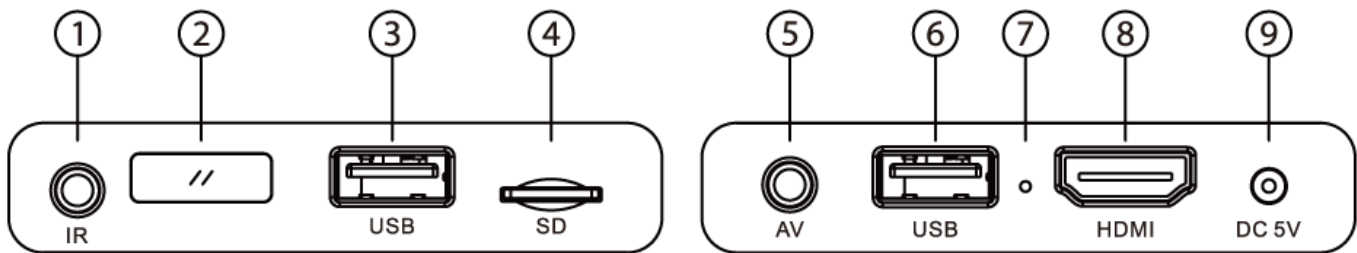

- 1 IR input jack for wired infrared remote sensor
- 2 Built-in remote control IR sensor window.
- 3 USB 2.0 connector for USB drives, keyboards, and mouse
- 4 Memory card reader for microSD cards
- 5 Analog AV to connect a TV with analog AV input only
- 6 USB 2.0 connector #1 for USB drives, keyboards, and mouse
- 7 Pin-hole button for forced firmware update. Please see the firmware update instructions
- 8 HDMI to connect to a TV or home theater with HDMI input
- 9 DC power connector for use with included power adapter

Note: The IR input jack is for use with optional external infrared remote control sensors (not included). An external remote control sensor allows the player to be hidden while the external remote control sensor is installed in clear view to receive signals from the remote control.

SETUP AND CONNECTIONS

Getting The Media Player Ready for Use

In the package are your new media player, an AC power adapter, a remote control, an AV cable, and this user's manual. To get your media player connected for use:

- Connect the media player to your TV using an HDMI cable (not included) or the included analog AV cable. It is possible to set the media player to send video via HDMI to your TV while sending the audio out via AV cable to a stereo system. When connecting to a 4K TV using HDMI, be sure to use an HDMI 2.0 cable
- Turn on your TV and set it to the appropriate input source where the media player is connected.
- Connect the AC adapter for the media player – it will turn on automatically. Ta-da!
- Install two AAA batteries (not included) into the remote control.

That's it! Now all you need to do is load some videos onto a Micro SD card or USB drive (not included) and begin enjoying your new media player.

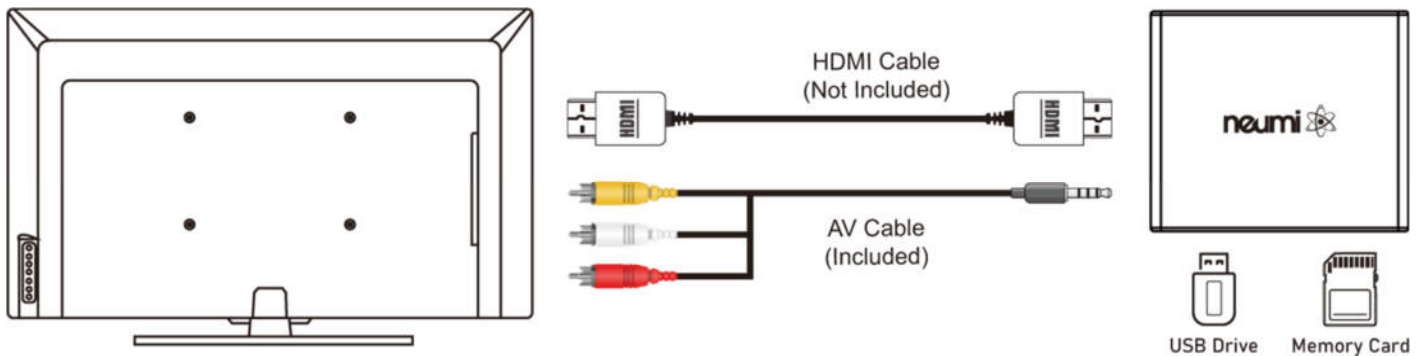

Note: By default, the media player will detect and use the highest resolution supported by the TV and HDMI cable it is connected to. The **Display Resolution** setting in the settings menu can be used to check and adjust the output resolution. If the media player is not sending a 4K video signal, make sure the TV's HDMI input supports 4K and the HDMI cable is version 2.0 or higher. Some TVs support 3840x2160 at 60Hz but 4096x2160 at only 30Hz – if your TV behaves this way, manually set the media player's **Display Resolution** to 3840x1060 60Hz for the best video quality.

LOADING VIDEOS, MUSIC, AND PHOTOS

Use a computer to copy videos, photos, or music onto a Micro SD card or USB drive (not included). Organize the files in folders to make them easier to manage. The player supports up to 1000 files per folder. If there are more than 1000 files in a folder, the additional files may not be read by the player.

After copying your media files, insert the Micro SD card or USB drive into the media player to play the videos, photos, or music.

Note: The media player does not have any internal memory. It must be used with a Micro SD card or a USB drive. If your Micro SD card or USB drive is not recognized, ensure it is using FAT32, exFAT, or NTFS file system format. For help connecting a storage device, please email SUPPORT@NEUMITECH.COM.

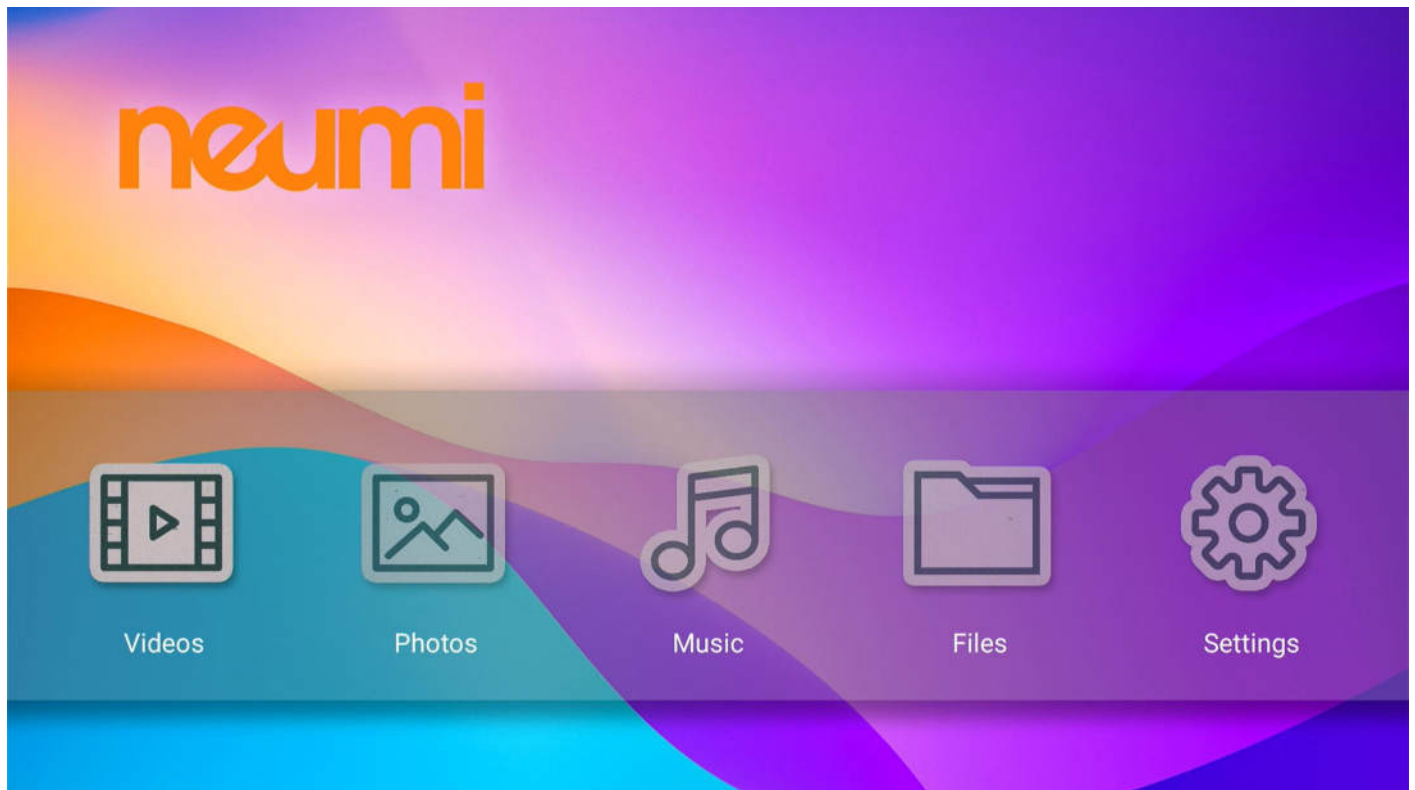

PLAYING VIDEOS

After powering on, the media player will display the main menu. Select the **Videos** icon from the main menu, then select the USB drive or Micro SD Card to browse for video files to play. Find the video you would like to play, press the **OK** button on the remote and it will begin playing. The media player can also be configured to automatically start playing videos whenever it is turned on – please refer to the settings section for how to configure and use this automatic playback feature.

During video playback, you can...

- Pause or resume playback using the **OK** button. Press the **Return** button to stop.
- Press the **Left/Right** buttons to quickly skip backward or forward. Press and hold the **Left/Right** buttons to use the timeline slider to quickly get to a point in the video.
- Additional photo display options are available by pressing the **Menu** button:

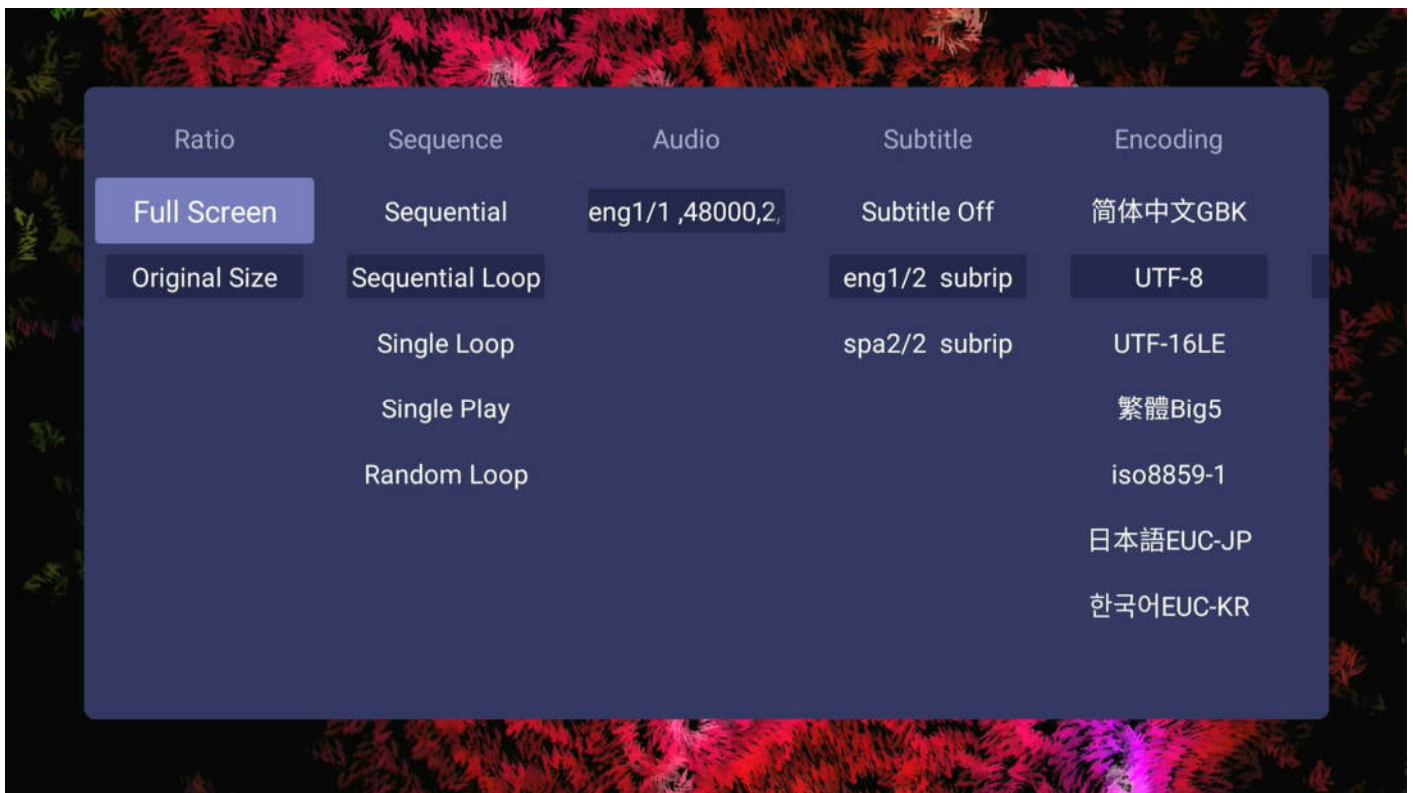

PLAYING VIDEOS

Ratio	Choose between stretched full screen or original aspect ratio
Sequence	Set the video playback repeat mode for one or all videos in the folder
Audio	Select which audio track to play
Subtitle	Select the subtitle track to display
Encoding	Select the subtitle text encoding
Size	Select the subtitle text size
Color	Select the subtitle text color

Note: Subtitle text encoding uses the UTF-8 code page by default. Due to the many ways in which text can be encoded, the only officially supported subtitle languages are English, Spanish, and Chinese even though other languages may be supported by the available encoding settings.

DISPLAYING SUBTITLES

The NEUMI ATOM 4K supports internal and external subtitles, including SRT, SUB+IDX, and PGS formats. If both internal and external subtitles are detected, they are listed together. To use an external subtitle file, name it the same as the video, but with a language and “SRT” file extension, and place it in the same folder as the video. For example:



To display subtitles, make sure Subtitle Display is turned on in the settings menu. Then, while playing the video, press the **Menu** button on the remote control to bring up the playback menu, select the subtitle track you want to display, and press the **OK** button to confirm.

PLAYING PHOTOS

From the main menu, select the **Photos** icon, then select the USB drive or Micro SD Card to browse for photos to play. Find the photo you would like to play, press the **OK** button on the remote and it will be displayed. The media player recognizes up to 1000 photos in a folder and can play a slideshow of photos within the same folder. The media player can also be configured to automatically start playing photos in a slideshow whenever it is turned on – please refer to the settings section for instructions.

During photo playback, you can...

- Pause or resume photo slideshow using the **OK** button. Press the **Return** button to stop.
- Use the **Left/Right** buttons on the remote to go to the previous or next photo.
- Additional photo display options are available by pressing the **Menu** button:



Effect	Sets the slideshow transition effect
Delay	Set the delay time between photos in a slideshow
Music	Play background music from the same folder as the photos
Ratio	Choose between stretched full screen or original aspect ratio
Sequence	Choose between sequential or random photo slideshow

Got Questions? Let Us Help! Email SUPPORT@NEUMITECH.COM

PLAYING MUSIC

From the main menu, select the **Music** icon, then select the USB drive or Micro SD Card to browse for music files to play. Find the file you would like to play, press the **OK** button on the remote and it will begin playing. The media player recognizes up to 1000 music files in a folder and can play through all files within the same folder. The media player can also be configured to automatically start playing music whenever it is turned on – please refer to the settings section for how to configure and use this automatic playback feature.

During music playback, you can...

- Pause or resume the song using the **OK** button. Press the **Return** button to stop.
- Press the **Left/Right** buttons to quickly skip backward or forward. Press and hold the **Left/Right** buttons to use the timeline slider to quickly get to a point in the song.
- Use the **Up/Down** buttons on the remote to go to the previous or next song.
- Use the **Menu** button to access the playback controls on the bottom of the screen, including playback order: Sequential, Sequential Loop, Single Loop, Random Loop.

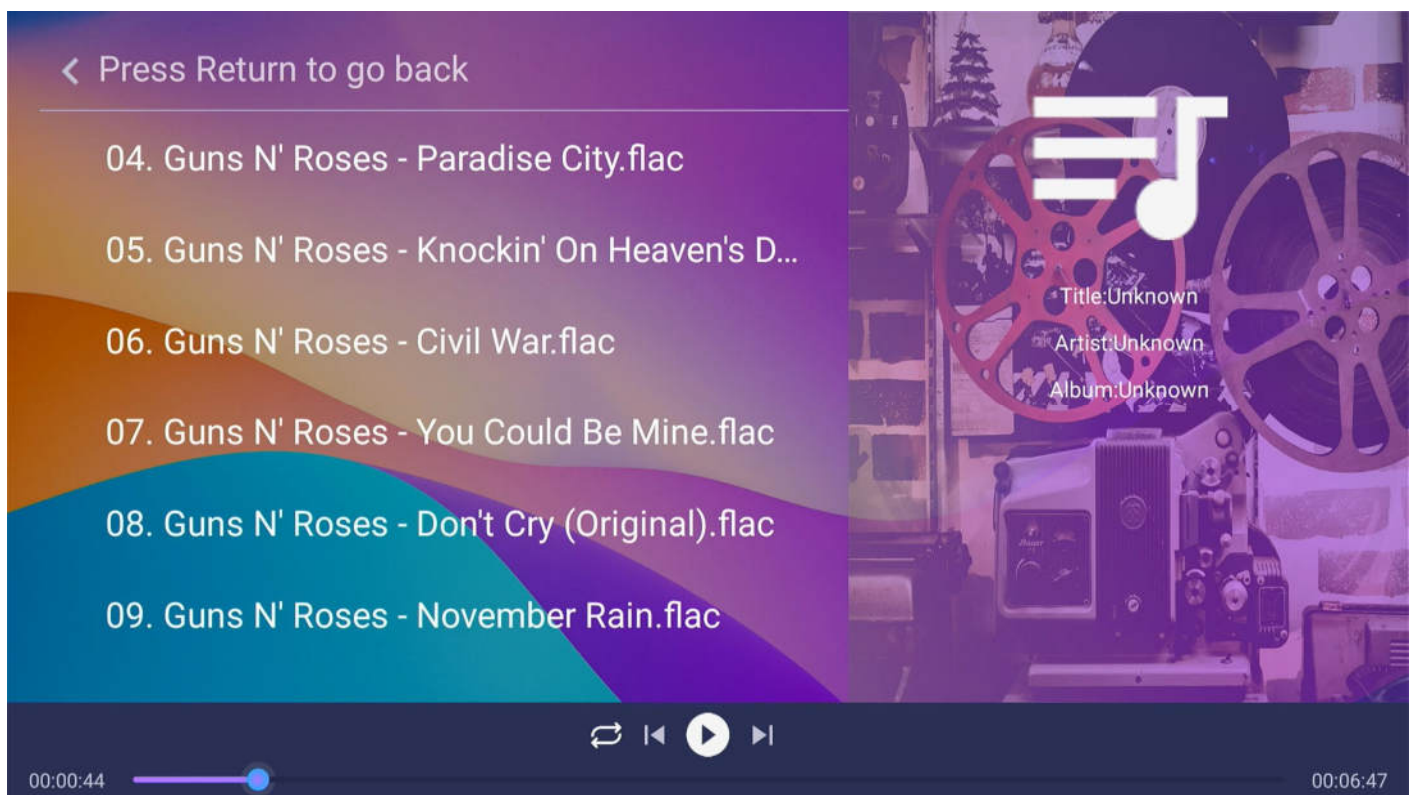

AUTOMATIC PLAYBACK

The NEUMI ATOM 4K can be configured to automatically play videos, photos, or music when:

- Power is plugged in, including when power is restored after an outage
- Turned on using the remote control
- A Micro SD card or USB drive is inserted

To enable this feature, go to the **Settings** menu and set the **Auto Play** setting to the media file type you want to automatically play, such as **Movies**, **Music**, or **Photos**. The **Videos+Photos** setting will first play videos followed by photos. The **Photos+Music** setting will play photos with background music.

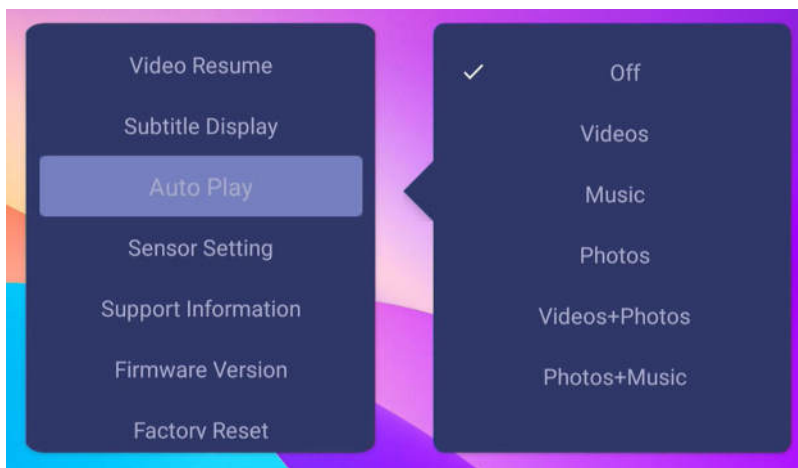

Make sure the videos, photos, and music files that you want to automatically play are in the root folder and not in any subfolders. To control the sequence of playback, name the files using a common format and in alphabetical order:

RIGHT!	WRONG!
VIDEO0001.MKV	1.MKV
VIDEO0002.MP4	02.MP4
VIDEO0003.MKV	3.MKV
...	...
VIDEO0010.MKV	10-Video.MKV
VIDEO0011.MKV	11(1).MKV
...	...
VIDEO0100.MP4	100.MP4

Note: When using the automatic playback feature, if it is desirable to always automatically start playing from the beginning of the first video, set Video Resume to Off.

COMMON QUESTIONS AND ANSWERS

Here are some common questions and answers. If you have additional questions, please email SUPPORT@NEUMITECH.COM for additional help!

Video does not play or plays with problems

The media player supports video, music, and photo files that meet the following requirements:

Video File Support

- Container files: MKV, MP4, MOV, VOB, AVI, TS, M2TS, WMV
- MPEG1, MPEG2, MPEG4/ASP, VP8 – maximum 1920x1080@60fps, 50mbps
- H.264/AVC, H.265/HEVC – maximum 4096x2304@60fps, 200mbps

Music File Support

- Formats: MP3, FLAC, OGG, APE, AAC
- Bitrate: 32kbps to 320kbps

Photo File Support

- Formats: JPG, PNG, GIF (non-animated), BMP

The most common cause for videos not playing is an unsupported video codec or a resolution that is higher than the maximum supported. You can use the free MediaInfo tool at <https://mediaarea.net/MediaInfoOnline> to check if your video satisfies these requirements. Videos that do not play can be re-coded using free software to be compatible. Please email our support team at SUPPORT@NEUMITECH.COM if you need help doing the conversion.

The USB drive or Micro SD card cannot be read

For USB drives and Micro SD cards, check that the drive is using FAT32, exFAT, or NTFS file system. Some drives come with hidden files from the factory that may cause error messages. Please try copying all files off of the drive, reformatting the drive, and then copying the files back onto the drive.

The media player does not support Micro SD cards or USB drives that other file systems such as HFS+, or EXT3/4. Please email SUPPORT@NEUMITECH.COM if you need help troubleshooting storage-related issues.

Photos are displayed sideways or upside down

The media player is designed to display photos as-is without making any changes to them. This ensures that your photos are never accidentally damaged or overwritten. The rotation function provided by the media player only changes how the current photo is shown on the screen – the rotation change is not saved to the photo file. Therefore, the next time the photo is shown, it is again displayed without any rotation applied.

Please visit WWW.NEUMITECH.COM for tutorials on how to fix image rotation issues using free software. Please email SUPPORT@NEUMITECH.COM if you need further help in this regard.

COMMON QUESTIONS AND ANSWERS

Photos have black bars on the sides or above/below

The media player shows all photos without cropping any portion of the photo. For photos that do not exactly match the display ratio of the TV screen, there will be black bars added to the sides or above/below the photo. This is normal behavior and your computer/phone works the same way. To eliminate black bars, make sure your photos are a perfect match for the resolution of the TV screen, such as 1920x1080.

The player does not respond to the remote control

To see if the remote is working, please use the cell phone trick where you look at the remote's signal emitter through your cell phone's camera. If you have an iPhone, use it in selfie mode with the front camera since the main camera has an IR filter. If the remote is working, you'll see the emitter light up through your phone's camera. This helps determine if the remote is bad. Please email SUPPORT@NEUMITECH.COM if you need additional assistance.

Low Audio Volume

The media player has a built-in volume control. By default, it is set to maximum but can be adjusted lower using the remote control. If the audio volume is low, try increasing the media player volume using the media player's remote control.

SETTINGS

Language - Sets the media player's operating language

Display Resolution - Sets the video output resolution. By selecting Auto, the player will attempt to determine the optimal resolution setting. If the media player is not sending a 4K video signal, make sure the TV's HDMI input supports 4K and the HDMI cable is version 2.0 or higher. Some TVs support 3840x2160 at 60Hz but 4096x2160 at only 30Hz – in this case, manually set the media player's **Display Resolution** to 3840x2160 60Hz.

Display Zoom - Adjusts the edge of the output image so that it properly fits the TV screen.

Display Rotation – Rotates the player's display by 90 or 270 degrees for use on a vertically mounted TV.

Audio Output - Sets the audio output format for HDMI. The Default setting is stereo PCM output. Select RAW Passthrough to send surround sound audio to a home theater receiver.

Video Resume - Remembers the stopping point of recently played videos and resumes playing from the stopping point. This capability can be used in conjunction with the Auto Play feature to automatically resume a video if power is lost and restored.

Subtitle Display - Sets the default subtitle display behavior when playing a video.

Auto Play - Automatically plays videos, music, or photos found on the root directory of a USB drive or Memory Card. The Videos+Photos option first plays videos and then photos. The Photos+Music option plays a photo slideshow with background music.

Support Information - Displays helpful technical support contact information.

Firmware Version** - Displays the current firmware version.

Factory Reset - When selected, resets all settings back to factory default. Please disconnect all drives from the media player before performing a factory reset.

**Firmware Updates – When available, firmware updates can be downloaded at WWW.NEUMITECH.COM.

SPECIFICATIONS

Video File Support

- Container files: MKV, MP4, MOV, VOB, AVI, TS, M2TS, WMV
- MPEG1, MPEG2, MPEG4/ASP, VP8 – maximum 1920x1080@60fps, 50mbps
- H.264/AVC, H.265/HEVC – maximum 4096x2304@60fps, 200mbps

Music File Support

- Formats: MP3, FLAC, OGG, APE, AAC
- Bitrate: 32kbps to 320kbps

Photo File Support

- Formats: JPG, PNG, GIF (non-animated), BMP

Storage Drive Support

- USB drives with FAT32, exFAT, or NTFS file systems
- Micro SD cards with FAT32, exFAT, or NTFS file systems

Video Output

- HDMI: 720p, 1080i, 1080p, 2160p, all @50Hz/60Hz
- AV: 720x576 (PAL), 720x480 (NTSC)

Audio Output

- HDMI: PCM, Passthrough
- AV: Stereo

Power Source:

- Included AC adapter: AC 90-230V 50/60Hz, 5V/2A DC Output

Dimensions:

- 2.95" x 2.52" x 0.55" (75mm x 64mm x 14mm), player alone
- Weight: 3 Ounce (85 Grams), player alone

FCC STATEMENT:

This device complies with Part 15 of the FCC Rules. Operation is subject to the following two conditions: (1) This device may not cause harmful interference. (2) This device must accept any interference received, including interference that may cause undesired operation.

neumi

LIMITED WARRANTY

The manufacturer warrants this product to be free from defects in workmanship and materials under normal use for one (1) year from the original purchase date. The manufacturer agrees, at its option during the warranty period, to repair any defect in material or workmanship or to furnish a repaired or refurbished product of equal value in exchange without charge (except for a fee for shipping, handling, packing, return postage, and insurance which will be incurred by the customer). Such repair or replacement is subject to verification of the defect or malfunction and proof of purchase as confirmed by showing the model number on the original dated sales invoice.

WARRANTY LIMITATIONS

This warranty does not include:

- Normal wear and tear
- Any condition resulting from other than ordinary use or any use for which the product was not intended
- Any condition resulting from incorrect or inadequate maintenance or care, modifications, misuse, abuse, negligence, accidents, or shipping damage
- Dissatisfaction due to buyer's remorse

The limit of liability under this warranty is the original purchase price of the product. The manufacturer makes no express warranty or condition whether written or oral and the manufacturer expressly disclaims all warranties and conditions not stated in this limited warranty. To the extent allowed by law, the manufacturer disclaims all implied warranties or conditions, including any implied warranties of merchantability and fitness for a particular purpose. For all transactions occurring in the United States, any implied warranty of condition of merchantability, satisfactory quality, or fitness for a particular purpose is limited to the duration of the express warranty set forth above. Some states or countries do not allow a limitation on how long an implied warranty lasts or the exclusion of limitation of incidental or consequential damages for consumer products. In such states or countries, some exclusions or limitations of this limited warranty may not apply to the customer. For consumer transactions, the limited warranty terms contained in this statement, except to the extent lawfully permitted, do not exclude, restrict, or modify but are in addition to the mandatory statutory rights applicable to the sale of this product to the customer.

WARRANTY CLAIMS

Claims for defective products must be made within one (1) year from the invoice date. Claims for missing parts must be made within 30 calendar days after the product is received. Any claim for defective merchandise returns must be packaged for adequate protection during shipping. All claims must provide a copy of the original invoice. If the claim is justified, the item(s) or part(s) will be repaired or replaced or a credit will be issued.
